

# Interactive C User's Guide

Manual Edition 0.9  
Documents software version 3.1  
April 18, 1997

Original document by:  
Fred Martin  
MIT Media Laboratory  
E-mail: fredm@media.mit.edu

Document currently maintained by:  
Anne Wright, Randy Sargent, and Carl Witty  
Newton Research Labs  
14813 NE 13th Street  
Bellevue, WA 98007  
E-mail: ic@newtonlabs.com  
<http://www.newtonlabs.com>

Copyright © 1997 Newton Research Labs.  
Copyright © 1992 Fred Martin  
All rights reserved.

# 1 Introduction

Interactive C (IC for short) is a C language consisting of a compiler (with interactive command-line compilation and debugging) and a run-time machine language module. IC implements a subset of C including control structures (`for`, `while`, `if`, `else`), local and global variables, arrays, pointers, structures, 16-bit and 32-bit integers, and 32-bit floating point numbers.

IC works by compiling into pseudo-code for a custom stack machine, rather than compiling directly into native code for a particular processor. This pseudo-code (or *p-code*) is then interpreted by the run-time machine language program. This unusual approach to compiler design allows IC to offer the following design tradeoffs:

- **Interpreted execution** that allows run-time error checking. For example, IC does array bounds checking at run-time to protect against some programming errors.
- **Ease of design.** Writing a compiler for a stack machine is significantly easier than writing one for a typical processor. Since IC's p-code is machine-independent, porting IC to another processor entails rewriting the p-code interpreter, rather than changing the compiler.
- **Small object code.** Stack machine code tends to be smaller than a native code representation.
- **Multi-tasking.** Because the pseudo-code is fully stack-based, a process's state is defined solely by its stack and its program counter. It is thus easy to task-switch simply by loading a new stack pointer and program counter. This task-switching is handled by the run-time module, not by the compiler.

Since IC's ultimate performance is limited by the fact that its output p-code is interpreted, these advantages are taken at the expense of raw execution speed.

*The current version of IC was designed and implemented by Randy Sargent, Anne Wright, and Carl Witty, with the assistance of Fred Martin. As of this writing, there are many related 6811 systems in use: the 6.270 LEGO Robot Controller Board (Rev 2.21: 1994, Rev 2.2: 1993, Rev 2.1: 1992, Rev 2.0: 1991), the Handy Board (1995), the Rug Warrior (1993), and the Sensor Robot (1991). This document currently specifically covers the Rev. 2.21 6.270 LEGO Robot Controller Board, but much of this manual is applicable to all platforms.*



## 2 Getting Started

IC runs on several different platforms (currently UNIX, Mac, and Win32 (Windows 95 and Windows NT)). These versions of IC are compatible with each other, but have different user interfaces. Please see the “Getting Started” section for the version you are using.

### 2.1 Getting Started under UNIX

You should have a file `ic_machine_3.1.tar.Z`, where `machine` is your machine type (for example, `ic_linux_3.1.tar.Z` or `ic_sparc_sunos_3.1.tar.Z`). (The version number may be different.) For clarity, I will continue this example with `ic_linux_3.1.tar.Z`; replace filenames as appropriate.

Type the following commands:

- `uncompress ic_linux_3.1.tar.Z`
- `tar xvf ic_linux_3.1.tar`

At this point, you should have a directory `ic_linux_3.1` with subdirectories `bin` and `libs`. The next step is to put these directories in their final resting place. If you have privileges on your machine, the best thing is probably to put the binaries in `/usr/local/bin` and the libraries in `/usr/local/lib/ic`. (The binaries come configured to expect libraries in this location). Otherwise, if you want to put the binaries and libraries somewhere else (such as in your home directory), you’ll need to re-configure the `ic` and `dl` executables (see Chapter 18 [Configuring IC under UNIX], page 79). *Warning: if you’re installing a new version of IC over a previous version of IC 3.1 or later, be sure to run the old version and write down the license key and name so that you can enter the information into your new copy.*

Before starting IC, you will need to know the name of the serial port you intend to use. The device names vary from system to system. Often, a serial port is set up to not give read and write permissions to standard users. Occasionally, a serial port is set up to run “getty”, which means the system thinks a serial terminal (such as a VT100) is connected, and that users will wish to log in. If in doubt, you should talk to your local system administrator to help you get started using the serial port.

Here are some typical serial port names, but realize that names sometimes vary even between different machines of the same architecture, so the following are suggestions for names to try, rather than the final answers:

- Linux: `‘/dev/ttyS0’`, `‘/dev/ttyS1’`, ...
- SPARC running SunOS: `‘/dev/ttya’`, `‘/dev/ttyb’`
- RS/6000: `‘/dev/tty0’`
- NeXTStation: `‘/dev/ttya’`, `‘/dev/ttyb’`
- DECstation and HP Snake: `‘/dev/tty00’`, `‘/dev/tty01’`

You may want to confirm that the serial port works before you try to use IC to talk to a board, as it is good to keep the number of unknowns to one at a time. One way to do this is to hook the serial port on your host machine to a serial source that is known to work (for instance, a modem or another serial port) and run `kermit`.

It is critical to get this step right before you continue. If you have not used serial ports on a UNIX machine before, I highly recommend you find someone more experienced to help you.

Now you should be ready to plug in your board. Refer to the owner's manual of your board for instructions.

If your board does not have “p-code” loaded, you will have to download the p-code before you can run IC. (Try turning your board on; if a message appears that starts “IC v3.1”, your board already has p-code loaded, and you can skip this step.) To download p-code, find the appropriate `.s19` file for your board in `/usr/local/lib/ic` (or wherever you placed the library files); this should be `pcode_hb.s19` for the Handy Board, `pcode_rw.s19` for the Rug Warrior, or `pcode22.s19` for the 6.270 board. Run the `d1` program that you just installed with the `.s19` file you've found, like `d1 pcode_hb.s19 -port /dev/cua0` (replace `/dev/cua0` with the serial port on your machine); follow the instructions that `d1` prints.

At this point you should be ready to run `ic`. Before you can run it, you'll have to enter a license key and name with `ic -config` (see Chapter 18 [Configuring IC under UNIX], page 79); you should have received a license key when you purchased IC.

Try running IC and typing “2+2”; you should get the response “Returned <int> 4”.

## 2.2 Getting Started on the Mac

You should have a file named `ic_mac_3.1.sea.hqx` (the version number may be different). You can convert this to `ic_mac_3.1.sea` with any of several popular format conversion tools, such as Compact Pro. Once you have the file `ic_mac_3.1.sea`, simply execute it; it will ask you where you want to place the Interactive C folder, and then extract the IC files in that location. *Warning: if you're upgrading from a previous version of IC 3.1 or later, don't delete the old version until you've run it and written down the license key and name so that you can enter the information into your new copy.*

Plug the board into one of your computer's serial ports, and run IC. The first time you run IC, it will ask you for your license key and name; you should have received a license key when you purchased IC.

Try turning your board on. If your board has its "p-code" loaded, a message should come up that starts "IC v3.1"; if it does not, you will have to reload the p-code. You can do this with the "Reload pcode..." command (on the File menu); the program will guide you through the steps.

Now you should be ready to use IC. Try running IC and typing "2+2"; you should get the response "Returned <int> 4".

## 2.3 Getting Started under Windows

You should have a file named `icw31.exe` (the version number may be different). CD to the directory where you want to install IC, and run `icw31.exe`. This will unpack `ic.exe` and the `libs` directory.

Plug the board into one of your computer's serial ports, and run IC. The first time you run IC, it will ask you for your license key and name; you should have received a license key when you purchased IC.

Try turning your board on. If your board has its "p-code" loaded, a message should come up that starts "IC v3.1"; if it does not, you will have to reload the p-code. You can do this with the "Reload PCode..." command (on the Board menu); the program will guide you through the steps.

Now you should be ready to use IC. Try running IC and typing "2+2"; you should get the response "Returned <int> 4".



## 3 Using IC

When IC is running and attached to a 6811 system, C expressions, function calls, and IC commands may be typed at the “C>” prompt.

For example, to evaluate the arithmetic expression  $1 + 2$ , type the following:

```
C> 1 + 2
```

When this expression is typed, it is compiled by the console computer and then downloaded to the 6811 system for evaluation. The 6811 then evaluates the compiled form and returns the result, which is printed on the console computer’s screen.

To evaluate a series of expressions, create a C block by beginning with an open curly brace { and ending with a close curly brace }. The following example creates a local variable *i* and prints 10 (the sum of *i* + 7) to the 6811’s LCD screen:

```
C>{int i=3; printf("%d", i+7);}
```

### 3.1 IC Commands

IC responds to the following commands:

**load *filename***

**Load file.** The command **load *filename*** compiles and loads the named file. The board must be attached for this to work. IC looks first in the local directory and then in the IC library path for files.

Several files may be loaded into IC at once, allowing programs to be defined in multiple files.

**unload *filename***

**Unload file.** The command **unload *filename*** unloads the named file, and re-downloads remaining files.

**list files**

The command **list files** displays the names of all files presently loaded into IC.

**list globals**

The command `list globals` displays the names of all currently defined global variables.

**list functions**

The command `list functions` displays the names of presently defined C functions.

**list defines**

The command `list defines` displays the names and values of all currently defined preprocessor macros.

**kill\_all** **Kill all processes.** The command `kill_all` kills all currently running processes.

**ps** **Print process status.** The command `ps` prints the status of currently running processes.

**help** **Help.** The command `help` displays a help screen of IC commands.

**quit** **Quit.** The command `quit` exits IC. `^c` can also be used.

## 3.2 Line Editing

IC has a built-in line editor and command history, allowing editing and re-use of previously typed statements and commands. The mnemonics for these functions are based on standard Emacs control key assignments.

To scan forward and backward in the command history, type `^p` or `UPARROW` for backward, and `^n` or `DOWNARROW` for forward.

*Under Windows, only the functionality described in the rest of this section is not available (only `^p`, `^n`, `UPARROW`, and `DOWNARROW` are available). However, normal Windows editing methods can be used.*

Under UNIX, an earlier line in the command history can be retrieved by typing the exclamation point followed by the first few characters of the line to retrieve, and then the space bar. For example, if you had previously typed the command `C> load foo.c`, then typing `C>!lo` followed by a space would retrieve the line `C> load foo`.

The following are the keystroke mappings understood by IC for the Mac and UNIX versions.

<b>Key</b>	<b>Function</b>
del	backward delete character
ctrl-d	forward delete character
ctrl-b, ←	go backward a character
ctrl-f, →	go forward a character
ctrl-A	go to beginning of line
ctrl-e	go to end of line
ctrl-k	kill line (from cursor forward)
ESC-d	forward kill word
ESC-DEL	backward kill word
↑, ctrl-p	history last
↓, ctrl-n	history next

The Mac and UNIX versions of IC do parenthesis-balance-highlighting as expressions are typed.

### 3.3 The `main()` Function

After functions have been downloaded to the board, they can be invoked from the IC prompt. If one of the functions is named `main()`, it will automatically be run when the board is reset.

To reset the board *without* running the `main()` function (for instance, when hooking the board back to the computer), hold down the board's `START` button (or `ESCAPE` on a 6.270 board) while pressing reset. The board will reset without running `main()`.



## 4 IC versus Standard C

The IC programming language is based loosely on ANSI C. However, there are major differences.

Many of these differences arise from the desire to have IC be “safer” than standard C. For instance, in IC, array bounds are checked at run time; for this reason, arrays cannot be converted to pointers in IC. Also, in IC, pointer arithmetic is not allowed.

Other differences are due to the desire that the IC runtime be small and efficient. For instance, the IC `printf` function does not understand many of the more exotic formatting options specified by ANSI C.

Yet other differences are due to the desire that IC be simpler than standard C. This is the reason for the global scope of all declarations.

In the rest of this document, when we refer to “C”, the statement applies to both IC and standard C. When we wish to specify one or the other, we will refer to either “IC” or “standard C”. When no such qualifiers are present, you should assume that we are talking about IC.



## 5 A Quick C Tutorial

Most C programs consist of function definitions and data structures. Here is a simple C program that defines a single function, called `main`.

```
void main()
{
    printf("Hello, world!\n");
}
```

All functions must have a return type. Since `main` does not return a value, it uses `void`, the null type, as its return type. Other types include integers (`int`) and floating point numbers (`float`). This *function declaration* information must precede each function definition.

Immediately following the function declaration is the function's name (in this case, `main`). Next, in parentheses, are any arguments (or inputs) to the function. `main` has none, but a empty set of parentheses is still required.

After the function arguments is an open curly-brace `{`. This signifies the start of the actual function code. Curly-braces signify program *blocks*, or chunks of code.

Next comes a series of C *statements*. Statements demand that some action be taken. Our demonstration program has a single statement, a `printf` (formatted print). This will print the message "Hello, world!" to the LCD display. The `\n` indicates end-of-line.

The `printf` statement ends with a semicolon (`;`). *All* C statements must be ended by a semicolon. Beginning C programmers commonly make the error of omitting the semicolon that is required at the end of each statement.

The `main` function is ended by the close curly-brace `}`.

Let's look at an another example to learn some more features of C. The following code defines the function `square`, which returns the mathematical square of a number.

```
int square(int n)
{
    return(n * n);
}
```

The function is declared as type `int`, which means that it will return an integer value. Next comes the function name `square`, followed by its argument list in parentheses. `square` has one argument, `n`, which is an integer. Notice how declaring the type of the argument is done similarly to declaring the type of the function.

When a function has arguments declared, those argument variables are valid within the “scope” of the function (i.e., they only have meaning within the function’s own code). Other functions may use the same variable names independently.

The code for `square` is contained within the set of curly braces. In fact, it consists of a single statement: the `return` statement. The `return` statement exits the function and returns the value of the C *expression* that follows it (in this case “`n * n`”).

Expressions are evaluated according set of precedence rules depending on the various operations within the expression. In this case, there is only one operation (multiplication), signified by the “`*`”, so precedence is not an issue.

Let’s look at an example of a function that performs a function call to the `square` program.

```
float hypotenuse(int a, int b)
{
    float h;

    h = sqrt((float)(square(a) + square(b)));

    return(h);
}
```

This code demonstrates several more features of C. First, notice that the floating point variable `h` is defined at the beginning of the `hypotenuse` function. In general, whenever a new program block (indicated by a set of curly braces) is begun, new local variables may be defined.

The value of `h` is set to the result of a call to the `sqrt` function. It turns out that `sqrt` is a built-in IC function that takes a floating point number as its argument.

We want to use the `square` function we defined earlier, which returns its result as an integer. But the `sqrt` function requires a floating point argument. We get around this type incompatibility by *coercing* the integer sum (`square(a) + square(b)`) into a float by preceding it with the desired type, in parentheses. Thus, the integer sum is made into a floating point number and passed along to `sqrt`.

The `hypotenuse` function finishes by returning the value of `h`.

This concludes the brief C tutorial.



## 6 Data Objects

Variables and constants are the basic data objects in a C program. Declarations list the variables to be used, state what type they are, and may set their initial value.

### 6.1 Variables

Variable names are case-sensitive. The underscore character is allowed and is often used to enhance the readability of long variable names. C keywords like `if`, `while`, etc. may not be used as variable names.

Global variables and functions may not have the same name. In addition, if a local variable is named the same as a global or a function, the use of that global or function is prevented within the scope of the local variable.

#### 6.1.1 Declaration

In C, variables can be declared at the top level (outside of any curly braces) or at the start of each block (a functional unit of code surrounded by curly braces). In general, a variable declaration is of the form:

```
<type> <variable name>;  
or  
<type> <variable name>=<initialization data>;
```

In C, `<type>` can be `int`, `long`, `float`, `char`, or `struct <struct name>`, and determines the *primary type* of the variable declared. This form changes somewhat when dealing with pointer and array declarations, which are explained in a later section, but in general this is the way you declare variables.

#### 6.1.2 Local and Global Scopes

If a variable is declared within a function, or as an argument to a function, its binding is *local*, meaning that the variable has existence only within that function definition.

If a variable is declared outside of a function, it is a global variable. It is defined for all functions, including functions which are defined in files other than the one in which the global variable was declared.

### 6.1.3 Variable Initialization

Local and global variables can be initialized to a value when they are declared. If no initialization value is given, the variable is initialized to zero.

All global variable declarations must be initialized to constant values. Local variables may be initialized to the value of arbitrary expressions including any globals, function calls, function arguments, or locals which have already been initialized.

Here is a small example of how initialized declarations are used.

```
int i=50;      /* declare i as global integer -- initial value 50 */
long j=100L;  /* declare j as global long -- initial value 100 */
int foo()
{
    int x;      /* declare x as local integer with initial value 0 */
    long y=j;   /* declare y as local integer with initial value j */
}
```

Local variables are initialized whenever the function containing them runs.

Global variables are initialized whenever a reset condition occurs. Reset conditions occur when:

1. Code is downloaded;
2. The `main()` procedure is run;
3. System hardware reset occurs.

### 6.1.4 Persistent Global Variables

A special *persistent* form of global variable, has been implemented for IC. A persistent global may be initialized just like any other global, but its value is only initialized when the code is downloaded and not on any other reset conditions. If no initialization information is included for

a persistent its value will be initialized to zero on download, but left unchanged on all other reset conditions.

To make a persistent global variable, prefix the type specifier with the keyword `persistent`. For example, the statement

```
persistent int i=500;
```

creates a global integer called `i` with the initial value 500.

Persistent variables keep their state when the board is turned off and on, when `main` is run, and when system reset occurs. Persistent variables will lose their state when code is downloaded as a result of loading or unloading a file. However, it is possible to read the values of your persistents in IC if you are still running the same IC session from which the code was downloaded. In this manner you could read the final values of calibration persistents, for example, and modify the initial values given to those persistents appropriately.

Persistent variables were created with two applications in mind:

- Calibration and configuration values that do not need to be re-calculated on every reset condition.
- Robot learning algorithms that might occur over a period when the robot is turned on and off.

## 6.2 Constants

### 6.2.1 Integer Constants

Integers constants may be defined in decimal integer format (e.g., 4053 or -1), hexadecimal format using the “0x” prefix (e.g., 0x1fff), and a non-standard but useful binary format using the “0b” prefix (e.g., 0b1001001). Octal constants using the zero prefix are not supported.

### 6.2.2 Long Integer Constants

Long integer constants are created by appending the suffix “l” or “L” (upper- or lower-case alphabetic L) to a decimal integer. For example, 0L is the long zero. Either the upper or lower-case “L” may be used, but upper-case is the convention for readability.

### 6.2.3 Floating Point Constants

Floating point numbers may use exponential notation (e.g., “10e3” or “10E3”) or may contain a decimal period. For example, the floating point zero can be given as “0.”, “0.0”, or “0E1”, but not as just “0”. *Since the 6811 has no floating point hardware, floating point operations are much slower than integer operations, and should be used sparingly.*

### 6.2.4 Characters and String Constants

Quoted characters return their ASCII value (e.g., 'x').

Character string constants are defined with quotation marks, e.g., "This is a character string."

### 6.2.5 NULL

The special constant NULL has the value of zero and can be assigned to and compared to pointer or array variables (which will be described in later sections). In general, you cannot convert other constants to be of a pointer type, so there are many times when NULL can be useful.

For example, in order to check if a pointer has been initialized you could compare its value to NULL and not try to access its contents if it was NULL. Also, if you had a defined a linked list type consisting of a value and a pointer to the next element, you could look for the end of the list by comparing the next pointer to NULL.

## 6.3 Data Types

IC supports the following data types:

## 16-bit Integers

16-bit integers are signified by the type indicator `int`. They are signed integers, and may be valued from -32,768 to +32,767 decimal.

## 32-bit Integers

32-bit integers are signified by the type indicator `long`. They are signed integers, and may be valued from -2,147,483,648 to +2,147,483,647 decimal.

## 32-bit Floating Point Numbers

Floating point numbers are signified by the type indicator `float`. They have approximately seven decimal digits of precision and are valued from about  $10^{-38}$  to  $10^{38}$ .

## 8-bit Characters

Characters are an 8-bit number signified by the type indicator `char`. A character's value typically represents a printable symbol using the standard ASCII character code, but this is not necessary; characters can be used to refer to arbitrary 8-bit numbers.

## Pointers

IC pointers are 16-bit numbers which represent locations in memory. Values in memory can be manipulated by calculating, passing and *dereferencing* pointers representing the location where the information is stored.

## Arrays

Arrays are used to store homogenous lists of data (meaning that all the elements of an array have the same type). Every array has a length which is determined at the time the array is declared. The data stored in the elements of an array can be set and retrieved in the same manner that other variables can be.

## Structures

Structures are used to store non-homogenous but related sets of data. Elements of a structure are referenced by name instead of number and may be of any supported type. Structures are useful for organizing related data into a coherent format, reducing the number of arguments passed to functions, increasing the effective number of values which can be returned by functions, and creating complex data representations such as directed graphs and linked lists.

### 6.4 Pointers

The address where a value is stored in memory is known as the *pointer* to that value. It is often useful to deal with pointers to objects, but great care must be taken to insure that the pointers used at any point in your code really do point to valid objects in memory. Attempts to refer to invalid memory locations could corrupt your memory. Most computing environments that you are probably used to return helpful messages like 'Segmentation Violation' or 'Bus Error' on attempts to access illegal memory. However, no such safety net exists in the 6.270 system and invalid pointer dereferencing is very likely to go undetected and cause serious damage to your data, your program, or even the pcode interpreter.

#### 6.4.1 Pointer Safety

In past versions of IC, you could not return pointers from functions or have arrays of pointers. In order to facilitate the use of structures, these features have been added to the current version. With this change, the number of opportunities to misuse pointers have increased. However, if you follow a few simple precautions you should do fine.

First, you should always check that the value of a pointer is not equal to NULL (a special zero pointer) before you try to access it. Variables which are declared to be pointers are initialized to NULL, so many uninitialized values could be caught this way.

Second, you should never use a pointer to a local variable in a manner which could cause it to be accessed after the function in which it was declared terminates. When a function terminates the space where its values were being stored is recycled. Therefore not only may dereferencing such pointers return incorrect values, but assigning to those addresses could lead to serious data corruption. A good way to prevent this is to never return the address of a local variable from the function which declares it and never store those pointers in an object which will live longer than

the function itself (a global pointer, array, or struct). Global variables and variables local to main will not move once declared and their pointers can be considered to be secure.

The type checking done by IC will help prevent many mishaps, but it will not catch all errors, so be careful.

## 6.4.2 Pointer Declaration and Use

A variable which is a pointer to an object of a given type is declared in the same manner as a regular object of that type, but with an extra `*` in front of the variable name.

The value stored at the location the pointer refers to is accessed by using the `*` operator before the expression which calculates the pointer. This process is known as dereferencing.

The address of a variable is calculated by using the `&` operator before that variable, array element, or structure element reference.

There are two main differences between how you would use a variable of a given type and a variable declared as a pointer to that type.

For the following explanation, consider `X` and `Xptr` as defined as follows:

```
long X;  
long *Xptr;
```

- Space Allocation – Declaring an object of a given type, as `X` is of type `long`, allocates the space needed to store that value. Because an IC `long` takes four bytes of memory, four bytes are reserved for the value of `X` to occupy. However, a pointer like `Xptr` does not have the same amount of space allocated for it that is needed for an object of the type it points to. Therefore it can only safely refer to space which has already been allocated for globals (in a special section of memory reserved for globals) or locals (temporary storage on the stack).
- Initial Value – It is always safe to refer to a non-pointer type, even if it hasn't been initialized. However pointers have to be specifically assigned to the address of legally allocated space or to the value of an already initialized pointer before they are safe to use.

So, for example, consider what would happen if the first two statements after `X` and `Xptr` were declared were the following:

```
X=50L;
*Xptr=50L;
```

The first statement is valid: it sets the value of `X` to 50L. The second statement would be valid if `Xptr` had been properly initialized, but in this case it is not. Therefore, this statement would corrupt memory.

Here is a sequence of commands you could try which illustrate how pointers and the `*` and `&` operators are used. It also shows that once a pointer has been set to point at a place in memory, references to it actually share the same memory as the object it points to:

```
X=50L; /* set the memory allocated for X to the value 50 */
Xptr=&X; /* set Xptr to point to X */
*Xptr; /* see that the value pointed at by Xptr is 50 */
X=100L; /* set X to the value 100 */
*Xptr; /* see that the value pointed at by Xptr changed to 100 */
*Xptr=200L; /* set the value pointed at by Xptr to 200 */
X; /* see that the value in X changed to 200 */
```

### 6.4.3 Passing Pointers as Arguments

Pointers can be passed to functions and functions can change the values of the variables that are pointed at. This is termed *call-by-reference*; a reference, or pointer, to a variable is given to the function that is being called. This is in contrast to *call-by-value*, the standard way that functions are called, in which the value of a variable is given to the function being called.

The following example defines an `average_sensor` function which takes a port number and a pointer to an integer variable. The function will average the sensor and store the result in the variable pointed at by `result`.

Function arguments are declared to be pointers by prepending a star to the argument name, just as is done for other variable declarations.

```
void average_sensor(int port, int *result)
{
    int sum= 0;
    int i;

    for (i= 0; i< 10; i++) sum += analog(port);

    *result= sum/10;
```

```
}
```

Notice that the function itself is declared as a `void`. It does not need to return anything, because it instead stores its answer in the pointer variable that is passed to it.

The pointer variable is used in the last line of the function. In this statement, the answer `sum/10` is stored at the location pointed at by `result`. Notice that the asterisk is used to assign a value to the *location* pointed by `result`.

#### 6.4.4 Returning Pointers from Functions

Pointers can also be returned from functions. Functions are defined to return pointers by preceding the name of the function with a star, just like any other type of pointer declaration.

```
int right,left;

int *dirptr(int dir)
{
    if(dir==0) {
        return(&right);
    }
    if(dir==1) {
        return(&left);
    }
    return(NULL);
}
```

The function `dirptr` returns a pointer to the global `right` when its argument `dir` is 0, a pointer to `left` when its argument is 1, and `NULL` if its argument is other than 0 or 1.

## 6.5 Arrays

IC supports arrays of characters, integers, long integers, floating-point numbers, structures, pointers, and array pointers (multi-dimensional arrays). While unlike regular C arrays in a number of respects, they can be used in a similar manner. The main reasons that arrays are useful are that they allow you to allocate space for many instances of a given type, send an arbitrary number of values to functions, and iterate over a set of values.

Arrays in IC are different and incompatible with arrays in other versions of C. This incompatibility is caused by the fact that references to IC arrays are checked to insure that the reference is truly within the bounds of that array. In order to accomplish this checking in the general case, it is necessary that the size of the array be stored with the contents of the array. *It is important to remember that an array of a given type and a pointer to the same type are incompatible types in IC, whereas they are largely interchangeable in regular C.*

### 6.5.1 Declaring and Initializing Arrays

Arrays are declared using square brackets. The following statement declares an array of ten integers:

```
int foo[10];
```

In this array, elements are numbered from 0 to 9. Elements are accessed by enclosing the index number within square brackets: `foo[4]` denotes the fifth element of the array `foo` (since counting begins at zero).

Arrays are initialized by default to contain all zero values. Arrays may also be initialized at declaration by specifying the array elements, separated by commas, within curly braces. If no size value is specified within the square brackets when the array is declared but initialization information is given, the size of the array is determined by the number of elements given in the declaration. For example,

```
int foo[] = {0, 4, 5, -8, 17, 301};
```

creates an array of six integers, with `foo[0]` equalling 0, `foo[1]` equalling 4, etc.

If a size is specified and initialization data is given, the length of the initialization data may not exceed the specified length of the array or an error results. If, on the other hand, you specify the size and provide fewer initialization elements than the total length of the array, the remaining elements are initialized to zero.

Character arrays are typically text strings. There is a special syntax for initializing arrays of characters. The character values of the array are enclosed in quotation marks:

```
char string[] = "Hello there";
```

This form creates a character array called `string` with the ASCII values of the specified characters. In addition, the character array is terminated by a zero. Because of this zero-termination, the character array can be treated as a string for purposes of printing (for example). Character arrays can be initialized using the curly braces syntax, but they will not be automatically null-terminated in that case. In general, printing of character arrays that are *not* null-terminated will cause problems.

## 6.5.2 Passing Arrays as Arguments

When an array is passed to a function as an argument, the array's pointer is actually passed, rather than the elements of the array. If the function modifies the array values, the array will be modified, since there is only one copy of the array in memory.

In normal C, there are two ways of declaring an array argument: as an array or as a pointer to the type of the array's elements. In IC array pointers are incompatible with pointers to the elements of an array so such arguments can only be declared as arrays.

As an example, the following function takes an index and an array, and returns the array element specified by the index:

```
int retrieve_element(int index, int array[])
{
    return array[index];
}
```

Notice the use of the square brackets to declare the argument `array` as a pointer to an array of integers.

When passing an array variable to a function, you are actually passing the value of the array pointer itself and not one of its elements, so no square brackets are used.

```
void foo()
{
    int array[10];

    retrieve_element(3, array);
}
```

### 6.5.3 Multi-dimensional Arrays

A two-dimensional array is just like a single dimensional array whose elements are one-dimensional arrays. Declaration of a two-dimensional array is as follows:

```
int k[2][3];
```

The number in the first set of brackets is the number of 1-D arrays of `int`. The number in the second set of brackets is the length of each of the 1-D arrays of `int`. In this example, `k` is an array containing two 1-D arrays; `k[0]` is a 1-D array of `int` of length 3; `k[0][1]` is an `int`. Arrays of with any number of dimensions can be generalized from this example by adding more brackets in the declaration.

### 6.5.4 Determining the size of Arrays at Runtime

An advantage of the way IC deals with arrays is that you can determine the size of arrays at runtime. This allows you to do size checking on an array if you are uncertain of its dimensions and possibly prevent your program from crashing.

*Since `_array_size` is not a standard C feature, code written using this primitive will only be able to be compiled with IC .*

The `_array_size` primitive returns the size of the array given to it regardless of the dimension or type of the array. Here is an example of declarations and interaction with the `_array_size` primitive:

```
int i[4]={10,20,30};
int j[3][2]={{1,2},{2,4},{15}};
int k[2][2][2];

_array_size(i); /* returns 4 */
_array_size(j); /* returns 3 */
_array_size(j[0]); /* returns 2 */
_array_size(k); /* returns 2 */
_array_size(k[0]); /* returns 2 */
```

## 6.6 Structures

Structures are used to store non-homogenous but related sets of data. Elements of a structure are referenced by name instead of number and may be of any supported type. Structures are useful for organizing related data into a coherent format, reducing the number of arguments passed to functions, increasing the effective number of values which can be returned by functions, and creating complex data representations such as directed graphs and linked lists.

The following example shows how to define a structure, declare a variable of structure type, and access its elements.

```
struct foo {
    int i;
    int j;
};

struct foo f1;

void set_f1(int i,int j)
{
    f1.i=i;
    f1.j=j;
}
void get_f1(int *i,int *j)
{
    *i=f1.i;
    *j=f1.j;
}
```

The first part is the structure definition. It consists of the keyword **struct**, followed by the name of the structure (which can be any valid identifier), followed by a list of named elements in curly braces. This definition specifies the structure of the type **struct foo**.

Once there is a definition of this form, you can use the type **struct foo** just like any other type. The line **struct foo f1;** is a global variable declaration which declares the variable **f1** to be of type **struct foo**.

The dot operator is used to access the elements of a variable of structure type. In this case, **f1.i** and **f1.j** refer to the two elements of **f1**. You can treat the quantities **f1.i** and **f1.j** just as you would treat any variables of type **int** (the type of the elements was defined in the structure declaration at the top to be **int**).

Pointers to structure types can also be used, just like pointers to any other type. However, with structures, there is a special short-cut for referring to the elements of the structure pointed to.

```
struct foo *fptr;

void main()
{
    fptr=&f1;
    fptr->i=10;
    fptr->j=20;
}
```

In this example, `fptr` is declared to be a pointer to type `struct foo`. In `main`, it is set to point to the global `f1` defined above. Then the elements of the structure pointed to by `fptr` (in this case these are the same as the elements of `f1`), are set. The arrow operator is used instead of the dot operator because `fptr` is a pointer to a variable of type `struct foo`. Note that `(*fptr).i` would have worked just as well as `fptr->i`, but it would have been clumsier.

Note that only pointers to structures, not the structures themselves, can be passed to or returned from functions.

## 6.7 Complex Initialization examples

Complex types – arrays and structures – may be initialized upon declaration with a sequence of constant values contained within curly braces and separated by commas. Arrays of character may also be initialized with a quoted string of characters.

For initialized declarations of single dimensional arrays, the length can be left blank and a suitable length based on the initialization data will be assigned to it. *Multi-dimensional arrays must have the size of all dimensions specified when the array is declared.* If a length is specified, the initialization data may not overflow that length in any dimension or an error will result. However, the initialization data may be shorter than the specified size and the remaining entries will be initialized to 0.

Following is an example of legal global and local variable initializations:

```
/* declare many globals of various types */
int i=50;

int *ptr=NULL;
```





## 7 Statements and Expressions

Operators act upon objects of a certain type or types and specify what is to be done to them. Expressions combine variables and constants to create new values. Statements are expressions, assignments, function calls, or control flow statements which make up C programs.

### 7.1 Operators

Each of the data types has its own set of operators that determine which operations may be performed on them.

#### 7.1.1 Integer Operations

The following operations are supported on integers:

- **Arithmetic.** addition `+`, subtraction `-`, multiplication `*`, division `/`.
- **Comparison.** greater-than `>`, less-than `<`, equality `==`, greater-than-equal `>=`, less-than-equal `<=`.
- **Bitwise Arithmetic.** bitwise-OR `|`, bitwise-AND `&`, bitwise-exclusive-OR `^`, bitwise-NOT `~`.
- **Boolean Arithmetic.** logical-OR `||`, logical-AND `&&`, logical-NOT `!`.

When a C statement uses a boolean value (for example, `if`), it takes the integer zero as meaning false, and any integer other than zero as meaning true. The boolean operators return zero for false and one for true.

Boolean operators `&&` and `||` will stop executing as soon as the truth of the final expression is determined. For example, in the expression `a && b`, if `a` is false, then `b` does not need to be evaluated because the result must be false. The `&&` operator therefore will not evaluate `b`.

#### 7.1.2 Long Integers

A subset of the operations implemented for integers are implemented for long integers: arithmetic addition `+`, subtraction `-`, and multiplication `*`, and the integer comparison operations. Bitwise and boolean operations and division are not supported.

### 7.1.3 Floating Point Numbers

IC uses a package of public-domain floating point routines distributed by Motorola. This package includes arithmetic, trigonometric, and logarithmic functions. Since floating point operations are implemented in software, they are much slower than the integer operations; we recommend against using floating point if you're concerned about performance.

The following operations are supported on floating point numbers:

- **Arithmetic.** addition `+`, subtraction `-`, multiplication `*`, division `/`.
- **Comparison.** greater-than `>`, less-than `<`, equality `==`, greater-than-equal `>=`, less-than-equal `<=`.
- **Built-in Math Functions.** A set of trigonometric, logarithmic, and exponential functions is supported. See Chapter 13 [Floating Point Functions], page 63, for details.

### 7.1.4 Characters

Characters are only allowed in character arrays. When a cell of the array is referenced, it is automatically coerced into a integer representation for manipulation by the integer operations. When a value is stored into a character array, it is coerced from a standard 16-bit integer into an 8-bit character (by truncating the upper eight bits).

## 7.2 Assignment Operators and Expressions

The basic assignment operator is `=`. The following statement adds 2 to the value of `a`.

```
a = a + 2;
```

The abbreviated form

```
a += 2;
```

could also be used to perform the same operation.

All of the following binary operators can be used in this fashion:

+ - \* / % << >> & ^ |

### 7.3 Increment and Decrement Operators

The increment operator “++” increments the named variable. For example, the statement “a++” is equivalent to “a= a+1” or “a+= 1”.

A statement that uses an increment operator has a value. For example, the statement

```
a= 3;
printf("a=%d a+1=%d\n", a, ++a);
```

will display the text “a=3 a+1=4.”

If the increment operator comes after the named variable, then the value of the statement is calculated *after* the increment occurs. So the statement

```
a= 3;
printf("a=%d a+1=%d\n", a, a++);
```

would display “a=3 a+1=3” but would finish with a set to 4.

The decrement operator “--” is used in the same fashion as the increment operator.

### 7.4 Data Access Operators

- &      A single ampersand preceding a variable, an array reference, or a structure element reference returns a pointer to the location in memory where that information is being stored. This should not be used on arbitrary expressions as they do not have a stable place in memory where they are being stored.
- \*      A single star preceding an expression which evaluates to a pointer returns the value which is stored at that address. This process of accessing the value stored within a pointer is known as dereferencing.
- [expr]      An expression in square braces following an expression which evaluates to an array (an array variable, the result of a function which returns an array pointer, etc.) checks

that the value of the expression falls within the bounds of the array and references that element.

- .
  - >
- A dot between a structure variable and the name of one of its fields returns the value stored in that field.
- An arrow between a pointer to a structure and the name of one of its fields in that structure acts the same as a dot does, except it acts on the structure pointed at by its left hand side. Where *f* is a structure of a type with *e* as an element name, the two expressions *f.i* and *(&f)->i* are equivalent.

## 7.5 Precedence and Order of Evaluation

The following table summarizes the rules for precedence and associativity for the C operators. Operators listed earlier in the table have higher precedence; operators on the same line of the table have equal precedence.

Operator	Associativity
() []	left to right
! ~ ++ -- - (type)	right to left
* / %	left to right
+ -	left to right
<< >>	left to right
< <= >	left to right
== !=	left to right
&	left to right
^	left to right
	left to right
&&	left to right
	right to left
= += -= etc.	right to left
,	left to right

## 8 Control Flow

IC supports most of the standard C control structures. One notable exception is the `switch` statement, which is not supported.

### 8.1 Statements and Blocks

A single C statement is ended by a semicolon. A series of statements may be grouped together into a *block* using curly braces. Inside a block, local variables may be defined.

### 8.2 If-Else

The `if else` statement is used to make decisions. The syntax is:

```
if (expression)
    statement-1
else
    statement-2
```

*expression* is evaluated; if it is not equal to zero (e.g., logic true), then *statement-1* is executed.

The `else` clause is optional. If the `if` part of the statement did not execute, and the `else` is present, then *statement-2* executes.

### 8.3 While

The syntax of a `while` loop is the following:

```
while (expression)
    statement
```

`while` begins by evaluating *expression*. If it is false, then *statement* is skipped. If it is true, then *statement* is evaluated. Then the expression is evaluated again, and the same check is performed. The loop exits when *expression* becomes zero.

One can easily create an infinite loop in C using the `while` statement:

```
while (1)
    statement
```

## 8.4 For

The syntax of a `for` loop is the following:

```
for (expr-1;expr-2;expr-3)
    statement
```

This is equivalent to the following construct using `while`:

```
expr-1;
while (expr-2) {
    statement
    expr-3;
}
```

Typically, *expr-1* is an assignment, *expr-2* is a relational expression, and *expr-3* is an increment or decrement of some manner. For example, the following code counts from 0 to 99, printing each number along the way:

```
int i;
for (i= 0; i < 100; i++)
    printf("%d\n", i);
```

## 8.5 Break

Use of the `break` provides an early exit from a `while` or a `for` loop.

## 9 LCD Screen Printing

IC has a version of the C function `printf` for formatted printing to the LCD screen.

The syntax of `printf` is the following:

```
printf(format-string, [arg-1] , ... , [arg-N] )
```

This is best illustrated by some examples.

### 9.1 Printing Examples

**Example 1: Printing a message.** The following statement prints a text string to the screen.

```
printf("Hello, world!\n");
```

In this example, the format string is simply printed to the screen.

The character `\n` at the end of the string signifies *end-of-line*. When an end-of-line character is printed, the LCD screen will be cleared when a subsequent character is printed. Thus, most `printf` statements are terminated by a `\n`.

**Example 2: Printing a number.** The following statement prints the value of the integer variable `x` with a brief message.

```
printf("Value is %d\n", x);
```

The special form `%d` is used to format the printing of an integer in decimal format.

**Example 3: Printing a number in binary.** The following statement prints the value of the integer variable `x` as a binary number.

```
printf("Value is %b\n", x);
```

The special form `%b` is used to format the printing of an integer in binary format. Only the *low byte* of the number is printed.

**Example 4: Printing a floating point number.** The following statement prints the value of the floating point variable `n` as a floating point number.

```
printf("Value is %f\n", n);
```

The special form `%f` is used to format the printing of floating point number.

**Example 5: Printing two numbers in hexadecimal format.**

```
printf("A=%x B=%x\n", a, b);
```

The form `%x` formats an integer to print in hexadecimal.

## 9.2 Formatting Command Summary

<code>%d</code>	Type: <code>int</code> Description: decimal number
<code>%x</code>	Type: <code>int</code> Description: hexadecimal number
<code>%b</code>	Type: <code>int</code> Description: low byte as binary number
<code>%c</code>	Type: <code>int</code> Description: low byte as ASCII character
<code>%f</code>	Type: <code>float</code> Description: floating point number
<code>%s</code>	Type: <code>char array</code> Description: char array (string)

## 9.3 Special Notes

- The final character position of the LCD screen is used as a system “heartbeat.” This character continuously blinks between a large and small heart when the board is operating properly. If the character stops blinking, the board has failed.
- Characters that would be printed beyond the final character position are truncated.
- When using a two-line display, the `printf()` command treats the display as a single longer line.
- Printing of long integers is not presently supported.

## 10 Preprocessor

The preprocessor processes a file before it is sent to the compiler. The IC preprocessor allows definition of macros, and conditional compilation of sections of code. Using preprocessor macros for constants and function macros can make IC code more efficient as well as easier to read. Using `#if` to conditionally compile code can be very useful, for instance, for debugging purposes.

### 10.1 Preprocessor Macros

Preprocessor macros are defined by using the `#define` preprocessor directive at the start of a line. If a macro is defined anywhere in any of the files loaded into IC, it can be used anywhere in any file. The following example shows how to define preprocessor macros.

```
#define RIGHT_MOTOR 0
#define LEFT_MOTOR 1

#define GO_RIGHT(power) (motor(RIGHT_MOTOR,(power)))
#define GO_LEFT(power) (motor(LEFT_MOTOR,(power)))

#define GO(left,right) {GO_LEFT(left); GO_RIGHT(right);}

void main()
{
    GO(0,0);
}
```

Preprocessor macro definitions start with the `#define` directive at the start of a line, and continue to the end of the line. After `#define` is the name of the macro, such as `RIGHT_MOTOR`. If there is a parenthesis directly after the name of the macro, such as the `GO_RIGHT` macro has above, then the macro has arguments. The `GO_RIGHT` and `GO_LEFT` macros each take one argument. The `GO` macro takes two arguments. After the name and the optional argument list is the body of the macro.

Each time a macro is invoked, it is replaced with its body. If the macro has arguments, then each place the argument appears in the body is replaced with the actual argument provided.

Invocations of macros without arguments look like global variable references. Invocations of macros with arguments look like calls to functions. To an extent, this is how they act. However, macro replacement happens before compilation, whereas global references and function calls happen

at run time. Also, function calls evaluate their arguments before they are called, whereas macros simply perform text replacement. For example, if the actual argument given to a macro contains a function call, and the macro instantiates its argument more than once in its body, then the function would be called multiple times, whereas it would only be called once if it were being passed as a function argument instead.

Appropriate use of macros can make IC programs and easier to read. It allows constants to be given symbolic names without requiring storage and access time as a global would. It also allows macros with arguments to be used in cases when a function call is desirable for abstraction, without the performance penalty of calling a function.

Macros defined in files can be used at the command line. Macros can also be defined at the commandline to be used in interactively, but these will not affect loads or compilation. To obtain a list of the currently defined macros, type `list defines` at the IC prompt.

## 10.2 Conditional compilation

It is sometimes desirable to conditionally compile code. The primary example of this is that you may want to perform debugging output sometimes, and disable it at other times. The IC preprocessor provides a convenient way of doing this by using the `#ifdef` directive.

```
void go_left(int power)
{
    GO_LEFT(power);
#ifdef DEBUG
    printf("Going Left\n");
    beep();
#endif
}
```

In this example, when the macro `DEBUG` is defined, the debugging message “Going Left” will be printed and the board will beep each time `go_left` is called. If the macro is not defined, the message and beep will not happen. Each `#ifdef` must be followed by an `#endif` at the end of the code which is being conditionally compiled. The macro to be checked can be anything, and `#ifdef` blocks may be nested.

Unlike regular C preprocessors, macros cannot be conditionally defined. If a macro definition occurs inside an `#ifdef` block, it will be defined regardless of whether the `#ifdef` evaluates to true or false. The compiler will generate a warning if macro definitions occur within an `#ifdef` block.

The `#if`, `#else`, and `#elif` directives are also available, but are outside the scope of this document. Refer to a C reference manual for how to use them.

### 10.3 Comparison with regular C preprocessors

The way in which IC deals with loading multiple files is fundamentally different from the way in which it is done in standard C. In particular, when using standard C, files are compiled completely independently of each other, then linked together. In IC, on the other hand, all files are compiled together. This is why standard C needs function prototypes and `extern` global definitions in order for multiple files to share functions and globals, while IC does not.

In a standard C preprocessor, preprocessor macros defined in one C file cannot be used in another C file unless defined again. Also, the scope of macros is only from the point of definition to the end of the file. The solution then is to have the prototypes, `extern` declarations, and macros in header files which are then included at the top of each C file using the `#include` directive. This style interacts well with the fact that each file is compiled independent of all the others.

However, since declarations in IC do not file scope, it would be inconsistent to have a preprocessor with file scope. Therefore, for consistency it was desirable to give IC macros the same behavior as globals and functions. Therefore, preprocessor macros have global scope. If a macro is defined anywhere in the files loaded into IC, it is defined everywhere. Therefore, the `#include` and `#undef` directives did not seem to have any appropriate purpose, and were accordingly left out.

The fact that `#define` directives contained within `#if` blocks are defined regardless of whether the `#if` evaluates to be true or false is a side effect of making the preprocessor macros have global scope.

Other than these modifications, the IC preprocessor should be compatible with regular C preprocessors.



## 11 The IC Library File

Library files provide standard C functions for interfacing with hardware on the robot controller board. These functions are written either in C or as assembly language drivers. Library files provide functions to do things like control motors, make tones, and input sensors values.

IC automatically loads the library file every time it is invoked. Depending on which 6811 board is being used, a different library file will be required. IC may be configured to load different library files as its default; the Windows and Mac versions of IC will automatically load the correct library for the board you're using at the moment.

This documentation covers the libraries for the Handy Board and 6.270 board (Rev. 2.21) only; if you have another board, see your owner's manual for documentation.

To understand better how the library functions work, study of the library file source code is recommended. The main library file for the Rev. 2.21 6.270 Board is named `lib_r22.lis`; for the Handy Board, the main library file is named `lib_hb.lis`.

### 11.1 Output Control

#### 11.1.1 DC Motors

The Handy Board has four motor ports, numbered from 0 to 3. The 6.270 board has 6 motor ports, numbered from 0 to 5; ports for motors 0 to 3 are located on the Microprocessor Board while motors 4 and 5 are located on the Expansion Board.

Motor may be set in a “forward” direction (corresponding to the green motor LED being lit) and a “backward” direction (corresponding to the motor red LED being lit).

The functions `fd(int m)` and `bk(int m)` turn motor `m` on forward or backward, respectively, at full power. The function `off(int m)` turns motor `m` off.

The power level of motors may also be controlled. This is done in software by turning a motor on and off rapidly (a technique called *pulse-width modulation*). The `motor(int m, int p)` function allows control of a motor's power level. Powers range from 100 (full on in the forward direction)

to -100 (full on the the backward direction). The system software actually only controls motors to seven degrees of power, but argument bounds of -100 and +100 are used.

```
void fd(int m)
```

Turns motor `m` on in the forward direction. Example: `fd(3);`

```
void bk(int m)
```

Turns motor `m` on in the backward direction. Example: `bk(1);`

```
void off(int m)
```

Turns off motor `m`. Example: `off(1);`

```
void alloff()
```

```
void ao()
```

 Turns off all motors. `ao` is a short form for `alloff`.

```
void motor(int m, int p)
```

Turns on motor `m` at power level `p`. Power levels range from 100 for full on forward to -100 for full on backward.

### 11.1.2 Servo Motor

Servos are motors with internal position feedback which you can accurately command to a given orientation. Servos will actively seek to move to and remain at the orientation they are commanded to go to. Servos are useful for aiming sensors or moving actuators through a limited arc. They are generally able to sweep through about 180 degrees and no more.

Library routines allows control of a single servo motor. The servo motor has a three-wire connection: power, ground, and control.

On a 6.270 board, there is a dedicated connection for the servo on the main board at the top of the bank of connectors which are above and to the left of the main power switch. A three prong connector with ground on the left, power in the middle, and control on the right should be used to plug the servo into its connector. So long as you are sure to get power in the middle, the servo will not be damaged by plugging it in backwards, but will simply not work until it is plugged in properly.

See *The Handy Board Technical Reference* for information on how to attach a servo motor to a Handy Board. To use these functions on a Handy Board, you must explicitly load the files `servo.c` and `servo.icb`.

The position of the servo motor shaft is controlled by a rectangular waveform that is generated on the A7 pin. The duration of the positive pulse of the waveform determines the position of the shaft. The acceptable width of the pulse varies for different models of servos, but is approximately 700 timer cycles minimum and 4000 timer cycles maximum, where the 6811's timer runs at 2MHz. The pulse is repeated approximately every 20 milliseconds.

`void servo_on()`

Turns the servo signal on. You must call this function before the servo will move.

`void servo_off()`

Turns servo signal off. The servo will no longer try to move to any particular position and will move freely. When you are not actively using the servo, turning it off will save power and processor cycles.

`int servo(int period)`

Sets the high time of the servo signal to `period` timer cycles so long as that falls within the acceptable range for the servo. Otherwise it truncates the value to the closest the servo is physically able to go to. It returns the thresholded version of the period you gave it. Remember that servos have a finite reaction time which, while very fast to human senses of time, is very slow to a processor. If you are resetting the servo angle in a tight loop it may well never catch up with you.

`int servo_rad(float angle)`

Sets the commanded orientation of the servo to approximately the angle in radians that it is given and returns the pulse width in timer counts which the servo was actually commanded with. The minimum pulse width is defined to be zero radians and the maximum is defined to be `pi` radians.

`int servo_deg(float angle)`

Sets the commanded orientation of the servo to approximately the angle in degrees that it is given and returns the pulse width in timer counts which the servo was actually commanded with. The minimum pulse width is defined to be zero degrees and the maximum is defined to be 180 degrees.

`int radian_to_pulse(float angle)`

Converts the angle given in radians to the corresponding pulse width in timer counts. Input range is 0.0 to 3.14.

`int degree_to_pulse(float angle)`

Converts the angle given in degrees to the corresponding pulse width in timer counts. Input range is 0.0 to 180.0.

### 11.1.3 Unidirectional Drivers

### 11.1.3.1 LED Drivers

On the 6.270 board, there are two output ports located on the Expansion Board that are suitable for driving LEDs or other small loads. These ports draw their power from the motor battery and hence will only work when that battery is connected.

The Handy Board does not include these ports.

The following commands are used to control the LED ports:

```
void led_out0(int s)
    Turns on LED0 port if s is non-zero; turns it off otherwise.

void led_out1(int s)
    Turns on LED1 port if s is non-zero; turns it off otherwise.
```

### 11.1.3.2 Expansion Board Motor Ports

On the 6.270 board, motor ports 4 and 5, located on the Expansion Board, may also be used to control unidirectional devices, such as a solenoid, lamp, or a motor that needs to be driven in one direction only. Each of the two motor ports, when used in this fashion, can independently control two such devices.

As mentioned above, the Handy Board does not have these ports.

To use the ports unidirectionally, the two-pin header directly beneath the motor 4 and 5 LEDs is used.

```
void motor4_left(int s)
    Turns on left side of motor 4 port if s is non-zero; turns it off otherwise.

void motor4_right(int s)
    Turns on right side of motor 4 port if s is non-zero; turns it off otherwise.

void motor5_left(int s)
    Turns on left side of motor 5 port if s is non-zero; turns it off otherwise.

void motor5_right(int s)
    Turns on right side of motor 5 port if s is non-zero; turns it off otherwise.
```

## 11.2 Sensor Input

### 11.2.1 Digital Input

`int digital(int p)`

Returns the value of the sensor in sensor port `p`, as a true/false value (1 for true and 0 for false).

Sensors are expected to be *active low*, meaning that they are valued at zero volts in the active, or true, state. Thus the library function returns the inverse of the actual reading from the digital hardware: if the reading is zero volts or logic zero, the `digital()` function will return true.

The 6.270 board has four DIP switches on the expansion board. The Handy Board does not have DIP switches.

`int dip_switch(int sw)`

Returns value of DIP switch `sw` on the expansion board. Switches are numbered from 1 to 4 as per labelling on the actual switch. Result is 1 if the switch is in the position labelled “on,” and 0 if not.

`int dip_switches()`

Returns value on DIP switches as a four-bit binary number. Left-most switch is most significant binary digit. “On” position is binary one.

Both the Handy Board and the 6.270 board have two buttons. On the Handy Board, the buttons are labelled `START` and `STOP`; on the 6.270 board, the buttons are labelled `ESCAPE` and `CHOOSE`.

`int stop_button()` (or `choose_button()` for the 6.270 board)

Returns value of button labelled `STOP` (or `CHOOSE`): 1 if pressed and 0 if released.

Example:

```
/* wait until stop button pressed */
while (!stop_button() {}
```

`int start_button()` (or `escape_button()`)

Returns value of button labelled `START` (or `ESCAPE`).

Example:

```
/* wait for button to be pressed; then
wait for it to be released so that
```

```

        button press is debounced          */
while (!start_button()) {}
while (start_button()) {}

```

The Handy Board has two additional convenience functions; these currently do not have analogs for the 6.270 board.

```
void stop_press()
```

Waits for the STOP button to be pressed, then released. Then issues a short beep and returns. The code for `stop_press()` is as follows:

```

while (!stop_button());
while (stop_button());
beep();

```

```
void start_press()
```

Like `stop_press()`, but for the START button.

## 11.2.2 Analog Inputs

```
int analog(int p)
```

Returns value of sensor port numbered `p`. Result is integer between 0 and 255.

If the `analog()` function is applied to a port that is implemented digitally in hardware, then the value 255 is returned if the *hardware* digital reading is 1 (as if a digital switch is open, and the pull up resistors are causing a high reading), and the value 0 is returned if the *hardware* digital reading is 0 (as if a digital switch is closed and pulling the reading near ground).

Ports are numbered as marked.

```
int knob() (or frob_knob() on the 6.270 board)
```

Returns a value from 0 to 255 based on the position of a potentiometer. On the 6.270 board, the potentiometer is labelled FROB KNOB.

The 6.270 board contains experimental circuitry for detecting the force being applied by a motor. The Handy Board does not contain this circuitry.

```
int motor_force(int m)
```

Returns value of analog input sensing current level through motor `m`. Result is integer between 0 and 255, but typical readings range from about 40 (low force) to 100 (high force).

The force-sensing circuitry functions properly only when motors are operated at full speed. The circuit returns invalid results when motors are pulse-width modulated because of spikes that occur in the feedback path.

The force-sensing circuitry is implemented for motors 0 through 3.

### 11.2.3 Infrared Subsystem

The infrared subsystem is composed of two parts: an infrared transmitter, and infrared receivers. Software is provided to control transmission frequency and detection of infrared light at two frequencies.

#### 11.2.3.1 Infrared Transmission

`void ir_transmit_on()`

Enables transmission of infrared light through IR OUT port.

`void ir_transmit_off()`

Disables transmission of infrared light through IR OUT port.

`void set_ir_transmit_period(int period)`

Sets infrared transmission period. `period` determines the delay in half-microseconds between transitions of the infrared waveform. If `period` is set to 10,000, a frequency of 100 Hz. will be generated. If `period` is set to 8,000, a frequency of 125 Hz. will be generated. The decoding software is capable of detecting transmissions on either of these two frequencies only.

`void set_ir_transmit_frequency(int frequency)`

Sets infrared transmission frequency. `frequency` is measured in hertz.

Upon a reset condition, the infrared transmission frequency is set for 100 Hz. and is disabled.

#### 11.2.3.2 Infrared Reception

In a typical 6.270 application, one robot will be broadcasting infrared at 100 Hz. and will set its detection system for 125 Hz. The other robot will do the opposite. Each robot must physically shield its IR sensors from its own light; then each robot can detect the emissions of the other.

The infrared reception software employs a *phase-locked loop* to detect infrared signals modulated at a particular frequency. This program generates an internal squarewave at the desired reception frequency and attempts to lock this squarewave into synchronization with a waveform received by an infrared sensor. If the error between the internal wave and the external wave is below some threshold, the external wave is considered “detected.” The software returns as a result the number of consecutive detections for each of the infrared sensor inputs.

While enabled, the infrared reception software requires a great deal of processor time. Therefore, it is desirable to disable the IR reception whenever it is not being actively used.

Up to four infrared sensors may be used. These are plugged into positions 4 through 7 of the digital input port. These ports and the remainder of the digital input port may be used without conflict for standard digital input while the infrared detection software is operating.

The following library functions control the infrared detection system:

`void ir_receive_on()`

Enables the infrared reception software. The default is disabled. When the software is enabled, between 20% and 30% of the 6811 processor time will be spent performing the detection function; therefore it should only be enabled if it is being used. *You must wait at least 100 milliseconds after starting the reception before the data is valid.*

`void ir_receive_off()`

Disables the infrared reception software.

`void set_ir_receive_frequency(int f)`

Sets the operating frequency for the infrared reception software. `f` should be 100 for 100 Hz. or 125 for 125 Hz. Default is 100.

`int ir_counts(int p)`

Returns number of consecutive squarewaves at operating frequency detected from port `p` of the digital input port. Result is number from 0 to 255. `p` must be 4, 5, 6, or 7

Random noise can cause spurious readings of 1 or 2 detections. The return value of `ir_counts()` should be greater than three before it is considered the result of a valid detection. *You must wait at least 100 milliseconds after starting the reception before the `ir_counts()` data is valid.*

### 11.2.4 Shaft Encoders

Shaft encoders can be used to count the number of times a wheel spins, or in general the number of digital pulses seen by an input. Two types of shaft encoders can be made using 6.270 sensors: optical encoders which use optical switches whose beam is periodically broken by a slotted wheel, or magnetic encoders which use Hall effect sensors which change state when a magnet on a shaft rotates past.

Shaft encoders are implemented using the input timer capture feature on the 6811. Therefore processing time is only used when a pulse is actually being recorded, and even very fast pulses can be counted. Digital ports 0 and 1 are two input capture channels which are available for use on the Handy Board and on the 6.270 board, so two channels of shaft encoding are supported.

The encoding software keeps a running count of the number of pulses each enabled encoder has seen. The number of counts is set to 0 when a channel is first enabled and when a user resets that channel. Because the counters are only 16-bits wide, they will overflow and the value will appear negative after 32,767 counts have been accumulated without a reset.

As shaft encoders are an optional feature, the library routines which read them are not loaded on start up.

In order to load the following routines for use in your programs, load the file `encoders.lis`. This file is in the standard IC library directory.

The actions of the shaft encoders are commanded and the results are read using the following routines. The argument `encoder` to each of the routines specifies which shaft encoder the function should affect. This value should be 0 for digital port 0 or one for digital port 1. Arguments out of the range 0 to 1 have no useful effect.

```
void enable_encoder(int encoder)
```

Enables the given encoder to start counting pulses and resets its counter to zero. By default encoders start in the disabled state and must be enabled before they start counting.

```
void disable_encoder(int encoder)
```

Disables the given encoder and prevents it from counting. Each shaft encoder uses processing time every time it receives a pulse while enabled, so they should be disabled when you no longer need the encoder's data.

```
void reset_encoder(int encoder)
```

Resets the counter of the given encoder to zero. For an enabled encoder, it is more efficient to reset its value than to use `enable_encoder()` to clear it.

```
int read_encoder(int encoder)
```

Returns the number of pulses counted by the given encoder since it was enabled or since the last reset, whichever was more recent.

## 11.3 Time Commands

System code keeps track of time passage in milliseconds. Library functions are provided to allow dealing with time in milliseconds (using long integers), or seconds (using floating point numbers).

```
void reset_system_time()
```

Resets the count of system time to zero milliseconds.

```
long mseconds()
```

Returns the count of system time in milliseconds. Time count is reset by hardware reset (i.e., pressing reset switch on board) or the function `reset_system_time()`. `mseconds()` is implemented as a C primitive (not as a library function).

```
float seconds()
```

Returns the count of system time in seconds, as a floating point number. Resolution is one millisecond.

```
void sleep(float sec)
```

Waits for an amount of time equal to or slightly greater than `sec` seconds. `sec` is a floating point number.

Example:

```
/* wait for 1.5 seconds */  
sleep(1.5);
```

```
void msleep(long msec)
```

Waits for an amount of time equal to or greater than `msec` milliseconds. `msec` is a long integer.

Example:

```
/* wait for 1.5 seconds */  
msleep(1500L);
```

## 11.4 Tone Functions

Two simple commands are provided for producing tones on the standard beeper.

`void beep()`

Produces a tone of 500 Hertz for a period of 0.3 seconds. Returns when the tone is finished.

`void tone(float frequency, float length)`

Produces a tone at pitch `frequency` Hertz for `length` seconds. Returns when the tone is finished. Both `frequency` and `length` are floats.

In addition to the simple tone commands, the following functions can be used asynchronously to control the beeper driver.

`void set_beeper_pitch(float frequency)`

Sets the beeper tone to be `frequency` Hz. The subsequent function is then used to turn the beeper on.

`void beeper_on()`

Turns on the beeper at last frequency selected by the former function. The beeper remains on until the `beeper_off` function is executed.

`void beeper_off()`

Turns off the beeper.

## 11.5 Menuing and Diagnostics Functions

These functions are not loaded automatically, but they are available for you to use if you wish. They currently work only on the 6.270 board, but could probably be ported to the Handy Board without too much trouble. They provide a standardized user interface for prompting users for input using the `CHOOSE` and `SELECT` buttons and the frob knob. You may wish to use this library for debugging the state of your robot while away from the terminal or for changing thresholds or gains on the fly.

### 11.5.1 menu.c

Load `menu.c` to be able to use these functions.

```
int select_string(char choices[][ ],int n)
```

Interactively selects a string from an array of string (two-dimensional array of characters) of length `n` and returns an integer when a button is pressed. If the button pressed was `CHOOSE`, it returns the index into the array of the selected string, otherwise it returns -1. Example of use:

```
char a[3][14]={"Analog Port ","Digital Port ","Quit"};
int port,index=select_string(a,3);

if(index>-1 && index<2)
    port=select_int_value(a[index],0,27);
```

```
int select_int_value(char s[],int min_val,int max_val)
```

```
float select_float_value(char s[],float min_val,float max_val)
```

Interactively selects and returns a number between `min_val` and `max_val` which is selected by adjusting the frob knob until the appropriate value is displayed then pressing a button. If `ESCAPE` was pressed, returns -1 (or -1.0) regardless of the value chosen. Otherwise returns the chosen value. Remember that the frob knob only returns one of 255 values, so if the range is greater than that not all values will be possible choices.

```
int chosen_button()
```

Checks the user buttons and returns `CHOOSE_B` if `CHOOSE` is pressed, `ESCAPE_B` if `ESCAPE` is pressed, and `NEITHER_B` if neither button is pressed. If both buttons are pressed, `CHOOSE` has priority.

```
int wait_button(int mode)
```

Waits for either user button to execute the action appropriate to `mode` then returns which button was pressed. The choices for `mode` are: `DOWN_B` – wait until either button is pressed; `UP_B` – wait until no buttons are pressed; `CYCLE_B` – wait until a button is depressed and then all depressed buttons are released before returning.

## 11.5.2 diagnostic.c

Load `menu.c` and `diagnostic.c` to be able to use these functions. You can easily copy `diagnostic.c` and modify the `control_panel` function to call your own routines.

```
void control_panel()
```

General purpose control panel to let you view inputs, frob outputs, or set A to D thresholds. Pressing `ESCAPE` from the main menu or selecting “Quit” exits the control panel.

```
int view_average_port(int port,int samples)
```

Displays the analog reading of the given port until a button is pressed. If the button is **CHOOSE**, it then samples the reading at the given port, averages **samples** readings together, then prints and returns the average result. If the button pushed was **ESCAPE**, it returns -1.

```
void view_inputs()
```

General purpose input status viewer using the standard menuing routines to show digital inputs, analog inputs, frob knob, dip switches, and motor force inputs. Pressing **ESCAPE** at any time exits the viewer.

```
void frob_outputs()
```

General purpose output frobber. Uses the standard menuing routines to let you control the motors, led outputs, ir output, and the servo. Pressing **ESCAPE** from the main menu or selecting "Quit" exits the frobber.



## 12 Multi-Tasking

### 12.1 Overview

One of the most powerful features of IC is its multi-tasking facility. Processes can be created and destroyed dynamically during run-time.

Any C function can be spawned as a separate task. Multiple tasks running the same code, but with their own local variables, can be created.

Processes communicate through global variables: one process can set a global to some value, and another process can read the value of that global.

Each time a process runs, it executes for a certain number of *ticks*, defined in milliseconds. This value is determined for each process at the time it is created. The default number of ticks is five; therefore, a default process will run for 5 milliseconds until its “turn” ends and the next process is run. All processes are kept track of in a *process table*; each time through the table, each process runs once (for an amount of time equal to its number of ticks).

Each process has its own *program stack*. The stack is used to pass arguments for function calls, store local variables, and store return addresses from function calls. The size of this stack is defined at the time a process is created. The default size of a process stack is 256 bytes.

Processes that make extensive use of recursion or use large local arrays will probably require a stack size larger than the default. Each function call requires two stack bytes (for the return address) plus the number of argument bytes; if the function that is called creates local variables, then they also use up stack space. In addition, C expressions create intermediate values that are stored on the stack.

It is up to the programmer to determine if a particular process requires a stack size larger than the default. A process may also be created with a stack size *smaller* than the default, in order to save stack memory space, if it is known that the process will not require the full default amount.

When a process is created, it is assigned a unique *process identification number* or *pid*. This number can be used to kill a process.

## 12.2 Creating New Processes

The function to create a new process is `start_process`. `start_process` takes one mandatory argument—the function call to be started as a process. There are two optional arguments: the process's number of ticks and stack size. (If only one optional argument is given, it is assumed to be the ticks number, and the default stack size is used.)

`start_process` has the following syntax:

```
int start_process(function-call(...), [TICKS], [STACK-SIZE])
```

`start_process` returns an integer, which is the process ID assigned to the new process.

The function call may be any valid call of the function used. The following code shows the function `main` creating a process:

```
void check_sensor(int n)
{
    while (1)
        printf("Sensor %d is %d\n", n, digital(n));
}

void main()
{
    start_process(check_sensor(2));
}
```

Normally when a C functions ends, it exits with a return value or the “void” value. If a function invoked as a process ends, it “dies,” letting its return value (if there was one) disappear. (This is okay, because processes communicate results by storing them in globals, not by returning them as return values.) Hence in the above example, the `check_sensor` function is defined as an infinite loop, so as to run forever (until the board is reset or a `kill_process` is executed).

Creating a process with a non-default number of ticks or a non-default stack size is simply a matter of using `start_process` with optional arguments; e.g.

```
start_process(check_sensor(2), 1, 50);
```

will create a `check_sensor` process that runs for 1 milliseconds per invocation and has a stack size of 50 bytes (for the given definition of `check_sensor`, a small stack space would be sufficient).

## 12.3 Destroying Processes

The `kill_process` function is used to destroy processes. Processes are destroyed by passing their process ID number to `kill_process`, according to the following syntax:

```
int kill_process(int pid);
```

`kill_process` returns a value indicating if the operation was successful. If the return value is 0, then the process was destroyed. If the return value is 1, then the process was not found.

The following code shows the `main` process creating a `check_sensor` process, and then destroying it one second later:

```
void main()
{
    int pid;

    pid= start_process(check_sensor(2));
    sleep(1.0);
    kill_process(pid);
}
```

## 12.4 Process Management Commands

IC has two commands to help with process management. The commands only work when used at the IC command line. They are not C functions that can be used in code.

`kill_all` kills all currently running processes.

`ps` prints out a list of the process status.

The following information is presented: process ID, status code, program counter, stack pointer, stack pointer origin, number of ticks, and name of function that is currently executing.

## 12.5 Process Management Library Functions

The following functions are implemented in the standard C library.

**void hog\_processor()**

Allocates an additional 256 milliseconds of execution to the currently running process. If this function is called repeatedly, the system will wedge and only execute the process that is calling `hog_processor()`. Only a system reset will unwedge from this state. Needless to say, this function should be used with extreme care, and should not be placed in a loop, unless wedging the machine is the desired outcome.

**void defer()**

Makes a process swap out immediately after the function is called. Useful if a process knows that it will not need to do any work until the next time around the scheduler loop. `defer()` is implemented as a C built-in function.

## 13 Floating Point Functions

In addition to basic floating point arithmetic (addition, subtraction, multiplication, and division) and floating point comparisons, a number of exponential and transcendental functions are built in to IC:

`float sin(float angle)`

Returns sine of `angle`. Angle is specified in radians; result is in radians.

`float cos(float angle)`

Returns cosine of `angle`. Angle is specified in radians; result is in radians.

`float tan(float angle)`

Returns tangent of `angle`. Angle is specified in radians; result is in radians.

`float atan(float angle)`

Returns arc tangent of `angle`. Angle is specified in radians; result is in radians.

`float sqrt(float num)`

Returns square root of `num`.

`float log10(float num)`

Returns logarithm of `num` to the base 10.

`float log(float num)`

Returns natural logarithm of `num`.

`float exp10(float num)`

Returns 10 to the `num` power.

`float exp(float num)`

Returns  $e$  to the `num` power.

`(float) a ^ (float) b`

Returns  $a$  to the  $b$  power.



## 14 Memory Access Functions

IC has primitives for directly examining and modifying memory contents. These should be used with care as it is easy to corrupt memory and crash the system using these functions.

`int peek(int loc)`

Returns the byte located at address `loc`.

`int peekword(int loc)`

Returns the 16-bit value located at address `loc` and `loc+1`. `loc` has the most significant byte, as per the 6811 16-bit addressing standard.

`void poke(int loc, int byte)`

Stores the 8-bit value `byte` at memory address `loc`.

`void pokeword(int loc, int word)`

Stores the 16-bit value `word` at memory addresses `loc` and `loc+1`.

`void bit_set(int loc, int mask)`

Sets bits that are set in `mask` at memory address `loc`.

`void bit_clear(int loc, int mask)`

Clears bits that are set in `mask` at memory address `loc`.



## 15 Error Handling

There are two types of errors that can happen when working with IC: *compile-time* errors and *run-time* errors.

Compile-time errors occur during the compilation of the source file. They are indicative of mistakes in the C source code. Typical compile-time errors result from incorrect syntax or mismatching of data types.

Run-time errors occur while a program is running on the board. They indicate problems with a valid C form when it is running. A simple example would be a divide-by-zero error. Another example might be running out of stack space, if a recursive procedure goes too deep in recursion.

These types of errors are handled differently, as is explained below.

### 15.1 Compile-Time Errors

When compiler errors occur, an error message is printed to the screen. All compile-time errors must be fixed before a file can be downloaded to the board.

### 15.2 Run-Time Errors

When a run-time error occurs, an error message is displayed on the LCD screen indicating the error number. If the board is hooked up to IC when the error occurs, a more verbose error message is printed on the terminal.

Here is a list of the run-time error codes:

- 1           no stack space for `start_process()`
- 2           no process slots remaining
- 3           array reference out of bounds
- 4           stack overflow error in running process
- 5           operation with invalid pointer

6	floating point underflow
7	floating point overflow
8	floating point divide-by-zero
9	number too small or large to convert to integer
10	tried to take square root of negative number
11	tangent of 90 degrees attempted
12	log or ln of negative number or zero
15	floating point format error in printf
16	integer divide-by-zero

## 16 Binary Programs

With the use of a customized 6811 assembler program, IC allows the use of machine language programs within the C environment. There are two ways that machine language programs may be incorporated:

1. Programs may be called from C as if they were C functions.
2. Programs may install themselves into the interrupt structure of the 6811, running repetitiously or when invoked due to a hardware or software interrupt.

When operating as a function, the interface between C and a binary program is limited: a binary program must be given one integer as an argument, and will return an integer as its return value. However, programs in a binary file can declare any number of global integer variables in the C environment. Also, the binary program can use its argument as a pointer to a C data structure.

### 16.1 The Binary Source File

Special keywords in the source assembly language file (or module) are used to establish the following features of the binary program:

#### **Entry point**

The entry point for calls to each program defined in the binary file.

#### **Initialization entry point**

Each file may have one routine that is called automatically upon a reset condition. (See Section 6.1.2 [Local and Global Scopes], page 17, for a discussion of global variable initialization.) This initialization routine is particularly useful for programs which will function as interrupt routines.

#### **C variable definitions**

Any number of two-byte C integer variables may be declared within a binary file. When the module is loaded into IC, these variables become defined as globals in C.

To explain how these features work, let's look at a sample IC binary source program:

```
/* Sample icb file */  
  
/* origin for module and variables */
```

```

        ORG     MAIN_START

/* program to return twice the argument passed to us */
subroutine_double:
    ASLD
    RTS

/* declaration for the variable "foo" */
variable_foo:
    FDB     55

/* program to set the C variable "foo" */
subroutine_set_foo:
    STD     variable_foo
    RTS

/* program to retrieve the variable "foo" */
subroutine_get_foo:
    LDD     variable_foo
    RTS

/* code that runs on reset conditions */
subroutine_initialize_module:
    LDD     #69
    STD     variable_foo
    RTS

```

The first statement of the file (“ORG MAIN\_START”) declares the start of the binary programs. This line must precede the code itself.

The entry point for a program to be called from C is declared with a special form beginning with the text `subroutine_`. In this case, the name of the binary program is `double`, so the label is named `subroutine_double`. As the comment indicates, this is a program that will double the value of the argument passed to it.

When the binary program is called from C, it is passed one integer argument. This argument is placed in the 6811’s D register (also known as the “Double Accumulator”) before the binary code is called.

The `double` program doubles the number in the D register. The `ASLD` instruction ( “Arithmetic Shift Left Double [Accumulator]”) is equivalent to multiplying by 2; hence this doubles the number in the D register.

The `RTS` instruction is “Return from Subroutine.” All binary programs must exit using this instruction. When a binary program exits, the value in the `D` register is the return value to `C`. Thus, the `double` program doubles its `C` argument and returns it to `C`.

### 16.1.1 Declaring Variables in Binary Files

The label `variable_foo` is an example of a special form to declare the name and location of a variable accessible from `C`. The special label prefix “`variable_`” is followed the name of the variable, in this case, “`foo`.”

This label must be immediately followed by the statement `FDB <number>`. This is an assembler directive that creates a two-byte value (which is the initial value of the variable).

Variables used by binary programs must be declared in the binary file. These variables then become `C` globals when the binary file is loaded into `C`.

The next binary program in the file is named “`set_foo`.” It performs the action of setting the value of the variable `foo`, which is defined later in the file. It does this by storing the `D` register into the memory contents reserved for `foo`, and then returning.

The next binary program is named “`get_foo`.” It loads the `D` register from the memory reserved for `foo` and then returns.

### 16.1.2 Declaring an Initialization Program

The label `subroutine_initialize_module` is a special form used to indicate the entry point for code that should be run to initialize the binary programs. This code is run upon standard reset conditions: program download, hardware reset, or running of the `main()` function.

In the example shown, the initialization code stores the value `69` into the location reserved for the variable `foo`. This then overwrites the `55` which would otherwise be the default value for that variable.

Initialization of global variables defined in an binary module is done differently than globals defined in `C`. In a binary module, the globals are initialized to the value declared by the `FDB` statement only when the code is downloaded to the 6811 board (not upon reset or running of `main`, like normal globals).

However, the initialization routine is run upon standard reset conditions, and can be used to initialize globals, as this example has illustrated.

## 16.2 Interrupt-Driven Binary Programs Before User Program Installation

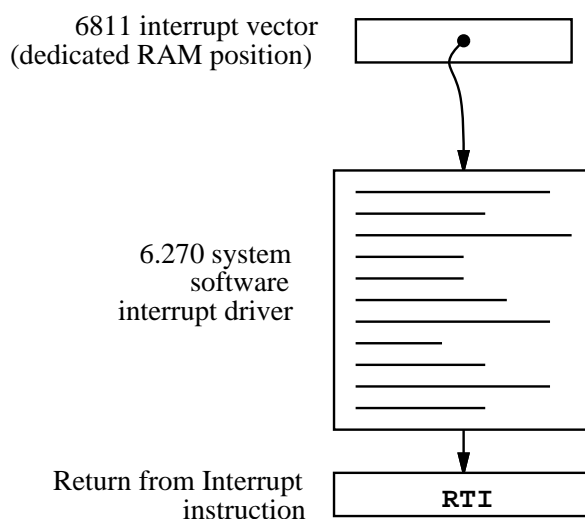

Interrupt-driven binary programs use the initialization sequence of the binary module to install a piece of code into the interrupt structure of the 6811.

The 6811 has a number of different interrupts, mostly dealing with its on-chip hardware such as timers and counters. One of these interrupts is used by the 6.270 software to implement time-keeping and other periodic functions (such as LCD screen management). This interrupt, dubbed the “System Interrupt,” runs at 1000 Hertz.

Instead of using another 6811 interrupt to run user binary programs, additional programs (that need to run at 1000 Hz. or less) may install themselves into the System Interrupt. User programs would then become part of the 1000 Hz interrupt sequence.

This is accomplished by having the user program “intercept” the original 6811 interrupt vector that points to 6.270 interrupt code. This vector is made to point at the user program. When user program finishes, it jumps to the start of the 6.270 interrupt code.

### After User Program Installation

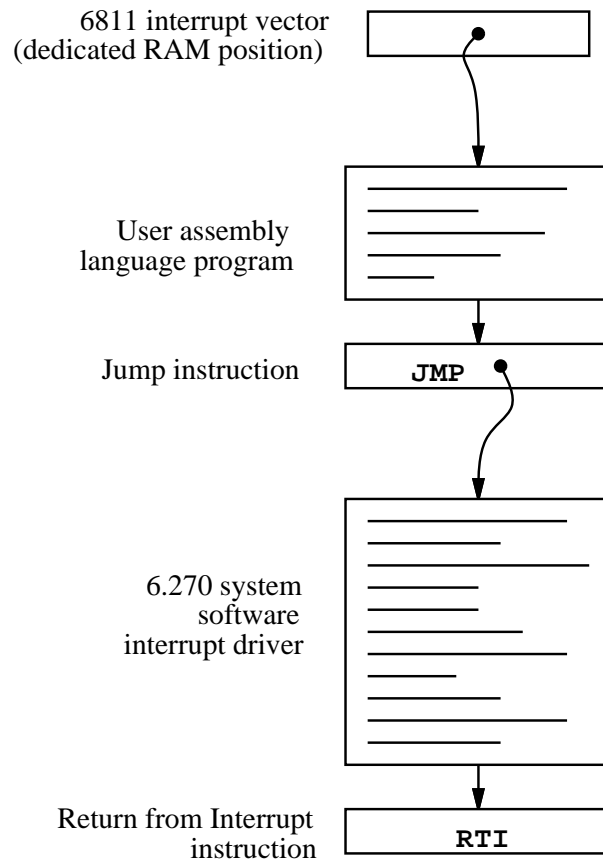

The first figure depicts the interrupt structure before user program installation. The 6811 vector location points to system software code, which terminates in a “return from interrupt” instruction.

The second figure illustrates the result after the user program is installed. The 6811 vector points to the user program, which exits by jumping to the system software driver. This driver exits as before, with the RTI instruction.

Multiple user programs could be installed in this fashion. Each one would install itself ahead of the previous one. Some standard 6.270 library functions, such as the shaft encoder software, is implemented in this fashion.

```
* icb file: "sysibeep.asm"
*
* example of code installing itself into
* SystemInt 1000 Hz interrupt
*
```

```

*   Fred Martin
*   Thu Oct 10 21:12:13 1991
*

#include <6811regs.asm>

        ORG     MAIN_START

subroutine_initialize_module:

#include <ldxibase.asm>
* X now has base pointer to interrupt vectors ($FF00 or $BF00)

* get current vector; poke such that when we finish, we go there
        LDD     TOC4INT,X           ; SystemInt on TOC4
        STD     interrupt_code_exit+1

* install ourself as new vector
        LDD     #interrupt_code_start
        STD     TOC4INT,X

        RTS

* interrupt program begins here
interrupt_code_start:
* frob the beeper every time called
        LDAA    PORTA
        EORA    #%00001000        ; beeper bit
        STAA    PORTA

interrupt_code_exit:
        JMP     $0000        ; this value poked in by init routine

```

The above program installs itself into the System Interrupt. This program toggles the signal line controlling the piezo beeper every time it is run; since the System Interrupt runs at 1000 Hz., this program will create a continuous tone of 500 Hz.

The first line after the comment header includes a file named “6811regs.asm”. This file contains equates for all 6811 registers and interrupt vectors; most binary programs will need at least a few of these. It is simplest to keep them all in one file that can be easily included. (This and other files included by the as11 assembler are located in the assembler’s default library directory, which is /mit/6.270/lib/as11/ on the MIT Athena system.)

The subroutine\_initialize\_module declaration begins the initialization portion of the program. The file “ldxibase.asm” is then included. This file contains a few lines of 6811 assembler

code that perform the function of determining the base pointer to the 6811 interrupt vector area, and loading this pointer into the 6811 X register.

The following four lines of code install the interrupt program (beginning with the label `interrupt_code_start`) according to the method described above.

First, the existing interrupt pointer is fetched. As indicated by the comment, the 6811's TOC4 timer is used to implement the System Interrupt. The vector is poked into the JMP instruction that will conclude the interrupt code itself.

Next, the 6811 interrupt pointer is replaced with a pointer to the new code. These two steps complete the initialization sequence.

The actual interrupt code is quite short. It toggles bit 3 of the 6811's PORTA register. The PORTA register controls the eight pins of Port A that connect to external hardware; bit 3 is connected to the piezo beeper.

The interrupt code exits with a jump instruction. The argument for this jump is poked in by the initialization program.

The method allows any number of programs located in separate files to attach themselves to the System Interrupt. Because these files can be loaded from the C environment, this system affords maximal flexibility to the user, with small overhead in terms of code efficiency.

### 16.3 The Binary Object File

The source file for a binary program must be named with the `.asm` suffix. Once the `.asm` file is created, a special version of the 6811 assembler program is used to construct the binary object code. This program creates a file containing the assembled machine code plus label definitions of entry points and C variables.

```
S116802005390037FD802239FC802239CC0045FD8022393C
S9030000FC
S116872B05390037FD872D39FC872D39CC0045FD872D39F4
S9030000FC
6811 assembler version 2.1 10-Aug-91
  please send bugs to Randy Sargent (rsargent@athena.mit.edu)
  original program by Motorola.
subroutine_double 872b *0007
```

```
subroutine_get_foo 8733 *0021
subroutine_initialize_module 8737 *0026
subroutine_set_foo 872f *0016
variable_foo 872d *0012 0017 0022 0028
```

The program `as11_ic` is used to assemble the source code and create a binary object file. It is given the filename of the source file as an argument. The resulting object file is automatically given the suffix `.icb` (for IC Binary). The binary object file that is created from the `testicb.asm` example file is shown above. Currently, `as11_ic` runs only under UNIX; if you need to create `.icb` files from another platform, you can use our ICB Assembler server on the World Wide Web (<http://www.newtonlabs.com/ic/icb.html>).

## 16.4 Loading an icb File

Once the `.icb` file is created, it can be loaded into IC just like any other C file. If there are C functions that are to be used in conjunction with the binary programs, it is customary to put them into a file with the same name as the `.icb` file, and then use a `.lis` file to load the two files together.

## 16.5 Passing Array Pointers to a Binary Program

A pointer to an array is a 16-bit integer address. To coerce an array pointer to an integer, use the following form:

```
array_ptr= (int) array;
```

where `array_ptr` is an integer and `array` is an array.

When compiling code that performs this type of pointer conversion, IC must be used in a special mode. Normally, IC does not allow certain types of pointer manipulation. To compile this type of code, use the following invocation:

```
ic -wizard
```

Arrays are internally represented with a two-byte length value followed by the array contents.

## 17 IC File Formats and Management

This section explains how IC deals with multiple source files.

### 17.1 C Programs

All files containing C code must be named with the “.c” suffix.

Loading functions from more than one C file can be done by issuing commands at the IC prompt to load each of the files. For example, to load the C files named `foo.c` and `bar.c`:

```
C> load foo.c
C> load bar.c
```

Alternatively, the files could be loaded with a single command:

```
C> load foo.c bar.c
```

### 17.2 List Files

If the program is separated into multiple files that are always loaded together, a “list file” may be created. This file tells IC to load a set of named files. Continuing the previous example, a file called `gnu.lis` can be created containing the following lines.:

```
foo.c
bar.c
```

Then typing the command `load gnu.lis` from the C prompt would cause both `foo.c` and `bar.c` to be loaded.

### 17.3 File and Function Management

### 17.3.1 Unloading Files

When files are loaded into IC, they stay loaded until they are explicitly unloaded. If one of the program files is being worked on, the other ones will remain in memory so that they don't have to be explicitly re-loaded each time the one undergoing development is reloaded.

However, suppose the file `foo.c` is loaded, which contains a definition for the function `main`. Then the file `bar.c` is loaded, which happens to also contain a definition for `main`. There will be an error message, because both files contain a `main`. IC will unload `bar.c`, due to the error, and re-download `foo.c` and any other files that are presently loaded.

The solution is to first unload the file containing the `main` that is not desired, and then load the file that contains the new `main`:

```
C> unload foo.c
C> load bar.c
```

## 18 Configuring IC under UNIX

IC has a multitude of command-line switches that allow control of a number of things. Explanations for these switches can be gotten by issuing the command “`ic -help`”.

IC stores the search path for and name of the library files internally; these may be changed by executing the command “`ic -config`”. When this command is run, IC will prompt for a new path and library file name, and will create a new executable copy of itself with these changes.

The `ic -config` command is also used to set your license key and name when first running IC.



# Table of Contents

<b>1</b>	<b>Introduction</b> .....	<b>1</b>
<b>2</b>	<b>Getting Started</b> .....	<b>3</b>
	2.1 Getting Started under UNIX .....	3
	2.2 Getting Started on the Mac .....	5
	2.3 Getting Started under Windows .....	5
<b>3</b>	<b>Using IC</b> .....	<b>7</b>
	3.1 IC Commands .....	7
	3.2 Line Editing .....	8
	3.3 The main() Function .....	9
<b>4</b>	<b>IC versus Standard C</b> .....	<b>11</b>
<b>5</b>	<b>A Quick C Tutorial</b> .....	<b>13</b>
<b>6</b>	<b>Data Objects</b> .....	<b>17</b>
	6.1 Variables .....	17
	6.1.1 Declaration .....	17
	6.1.2 Local and Global Scopes .....	17
	6.1.3 Variable Initialization .....	18
	6.1.4 Persistent Global Variables .....	18
	6.2 Constants .....	19
	6.2.1 Integer Constants .....	19
	6.2.2 Long Integer Constants .....	20
	6.2.3 Floating Point Constants .....	20
	6.2.4 Characters and String Constants .....	20
	6.2.5 NULL .....	20
	6.3 Data Types .....	20
	6.4 Pointers .....	22
	6.4.1 Pointer Safety .....	22
	6.4.2 Pointer Declaration and Use .....	23
	6.4.3 Passing Pointers as Arguments .....	24
	6.4.4 Returning Pointers from Functions .....	25
	6.5 Arrays .....	25
	6.5.1 Declaring and Initializing Arrays .....	26

6.5.2	Passing Arrays as Arguments .....	27
6.5.3	Multi-dimensional Arrays .....	28
6.5.4	Determining the size of Arrays at Runtime .....	28
6.6	Structures .....	29
6.7	Complex Initialization examples .....	30
<b>7</b>	<b>Statements and Expressions .....</b>	<b>33</b>
7.1	Operators .....	33
7.1.1	Integer Operations .....	33
7.1.2	Long Integers .....	33
7.1.3	Floating Point Numbers .....	34
7.1.4	Characters .....	34
7.2	Assignment Operators and Expressions .....	34
7.3	Increment and Decrement Operators .....	35
7.4	Data Access Operators .....	35
7.5	Precedence and Order of Evaluation .....	36
<b>8</b>	<b>Control Flow .....</b>	<b>37</b>
8.1	Statements and Blocks .....	37
8.2	If-Else .....	37
8.3	While .....	37
8.4	For .....	38
8.5	Break .....	38
<b>9</b>	<b>LCD Screen Printing .....</b>	<b>39</b>
9.1	Printing Examples .....	39
9.2	Formatting Command Summary .....	40
9.3	Special Notes .....	40
<b>10</b>	<b>Preprocessor .....</b>	<b>41</b>
10.1	Preprocessor Macros .....	41
10.2	Conditional compilation .....	42
10.3	Comparison with regular C preprocessors .....	43
<b>11</b>	<b>The IC Library File .....</b>	<b>45</b>
11.1	Output Control .....	45
11.1.1	DC Motors .....	45
11.1.2	Servo Motor .....	46
11.1.3	Unidirectional Drivers .....	47
11.1.3.1	LED Drivers .....	48
11.1.3.2	Expansion Board Motor Ports .....	48

11.2	Sensor Input .....	49
11.2.1	Digital Input .....	49
11.2.2	Analog Inputs .....	50
11.2.3	Infrared Subsystem .....	51
11.2.3.1	Infrared Transmission .....	51
11.2.3.2	Infrared Reception .....	51
11.2.4	Shaft Encoders .....	53
11.3	Time Commands .....	54
11.4	Tone Functions .....	55
11.5	Menuing and Diagnostics Functions .....	55
11.5.1	menu.c .....	55
11.5.2	diagnostic.c .....	56
<b>12</b>	<b>Multi-Tasking .....</b>	<b>59</b>
12.1	Overview .....	59
12.2	Creating New Processes .....	60
12.3	Destroying Processes .....	61
12.4	Process Management Commands .....	61
12.5	Process Management Library Functions .....	61
<b>13</b>	<b>Floating Point Functions .....</b>	<b>63</b>
<b>14</b>	<b>Memory Access Functions .....</b>	<b>65</b>
<b>15</b>	<b>Error Handling .....</b>	<b>67</b>
15.1	Compile-Time Errors .....	67
15.2	Run-Time Errors .....	67
<b>16</b>	<b>Binary Programs .....</b>	<b>69</b>
16.1	The Binary Source File .....	69
16.1.1	Declaring Variables in Binary Files .....	71
16.1.2	Declaring an Initialization Program .....	71
16.2	Interrupt-Driven Binary Programs .....	72
16.3	The Binary Object File .....	75
16.4	Loading an icb File .....	76
16.5	Passing Array Pointers to a Binary Program .....	76
<b>17</b>	<b>IC File Formats and Management .....</b>	<b>77</b>
17.1	C Programs .....	77
17.2	List Files .....	77
17.3	File and Function Management .....	77

17.3.1	Unloading Files .....	78
<b>18</b>	<b>Configuring IC under UNIX.....</b>	<b>79</b>